



# CT02 Belt Conveyor Decline 400V



# Smart & flexible

The modular platform of Inther Conveyor Equipment (ICE) is unique due to the short installation and commissioning time. All components (both mechanical and electrical) come pre-installed in our modules, including cabling and the correct E-plan codes.

The smart and flexible modules are available in various widths and are suitable for transporting all common goods in intralogistics.



## Decline 400V

The CT02 Belt Conveyor Decline 400V transports materials using a driven conveyor belt. With this module it is possible for materials to descend from a higher level.

- > Fully modular
- > Integrated and labeled cabling
- > Fast installation time

### Technical specifications

#### General information

Max. carrying weight	50 kg/m
Transport speed	Min. 0.23 / max. 1.2 m/sec.
Max. lowering angle	18°
Ambient temperature	+5°C to +40°C

#### Drive transport

Drive	General Drive 400V
Drive coupling	Toothed belt

#### Electrical connection

Connection voltage	400V AC / 3-phase
Nominal current	1.0A - 2.8A
Sensor	Retro-reflective, installed and cabled

#### Dimensions

LW effective width	420/620 mm
ML max. module length	21000 mm
TW module width	LW + 96 mm
SF side guide	80 mm
FL Feed length	747 - 1047 mm
AL Arch length	433 - 733 mm
$\alpha$ lowering angle	0° - 18°





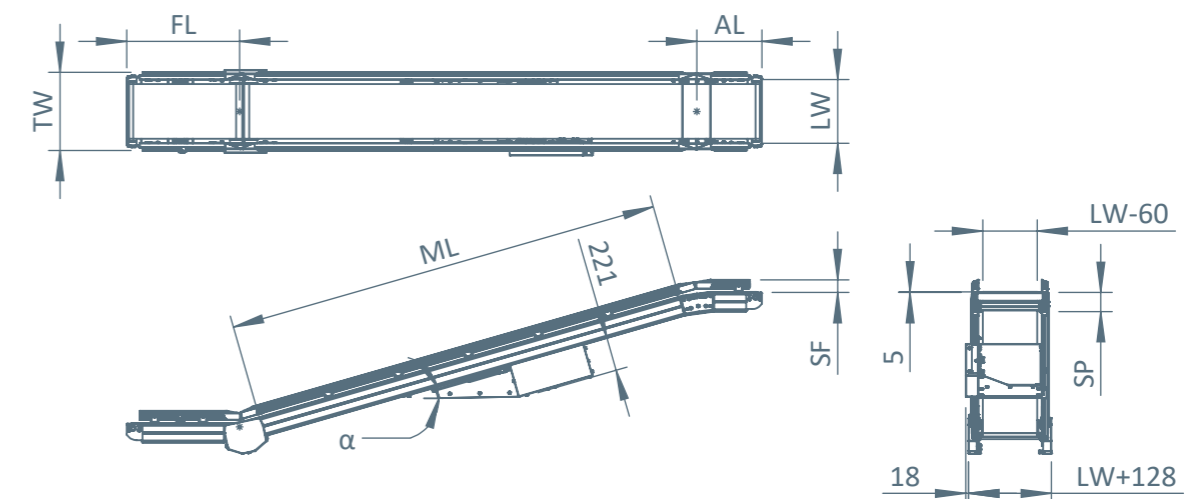

#### Side profile

SP Profile height	126 mm
-------------------	--------



# Inther

## Conveyor Equipment

-  The Netherlands (HQ)
-  Germany
-  Belgium
-  Moldova
-  USA
-  China
  - › Shanghai
  - › Suzhou



[info@inthergroup.com](mailto:info@inthergroup.com)  
[www.inthergroup.com](http://www.inthergroup.com)

**IN-HER**  
improving intralogistics